



VePAL CX150-D3+

Handheld CATV Test Set

CATV and DOCSIS® network testing simplified

The CX150-D3+ is a compact installation meter designed for analog and digital cable TV networks supporting VoIP and Internet services.



Platform Highlights

- Intuitive presentation of measurements with test graphics
- High resolution color touch-screen viewable in any lighting condition fitted with protective cover
- Robust, handheld chassis packed with powerful and flexible features for demanding environments and test conditions
- Optimized for field engineers or technicians installing and maintaining CATV networks enabling triple play services
- Ethernet port and connection for back office applications, workforce management and triple play service verification
- USB memory stick, Bluetooth adaptor, and FTP upload capability for test result storage and file transfer respectively
- Maintain instrument software, manage test configurations, process measurement results and generate customer test reports using included ReVeal™ PC software
- Extend field testing time using interchangeable Lilon battery pack/s. Greater battery autonomy provided in standby mode
- Supports advanced IP testing; Ping, Trace Route, ARP Wiz, VoIP, VeTest, WiFi, Web browser, and FTP upload/download
- Perform remote testing and monitoring using the remote control option via standard Ethernet interface
- NetWiz cable diagnosis with network statistics*
- VoIP call emulation and MOS performance analysis*
- WiFi Wiz site survey with Internet and VoIP check*

Key Features

- Frequency analysis from 5 to 1000 MHz
- Supports Annex A and B signal formats
- Comprehensive SLM features including single channel measurement, system scan, tilt, and installation check
- Measure power level of NTSC, PAL and SECAM video signals
- Carrier-to-Noise (C/N); Adjacent Channel measurement ratio
- MER and Pre/Post BER measurements of QAM carriers with Constellation diagram and Histogram
- Return Path and Forward Path Ingress Scan with 50 dB dynamic range
- Reverse Path QAM16/64/128 MER, Pre/Post BER measurement with Constellation diagram*
- Equalized/unequalized MER and BER measurements
- DOCSIS 3.0/EuroDOCSIS 3.0 8x4 modem emulation with VeTest Throughput
- Upstream Signal Generator (USG)
- Return Path Balancing* (*requires 2-port configuration*)
- Home Installation Process/Certification Auto Tests*

*Optional

Applications

VeEX® VePAL CX instruments are next generation test solutions to install and maintain analog and digital cable TV networks offering Triple Play services. All CX products are lightweight, rugged and weather resistant and feature signal level meter capabilities. Certain models can be equipped with a cable modem option to validate DOCSIS and Euro DOCSIS based networks while some units can be equipped with an Upstream Signal Generator to support QAM signal generation for reverse path QAM analysis.

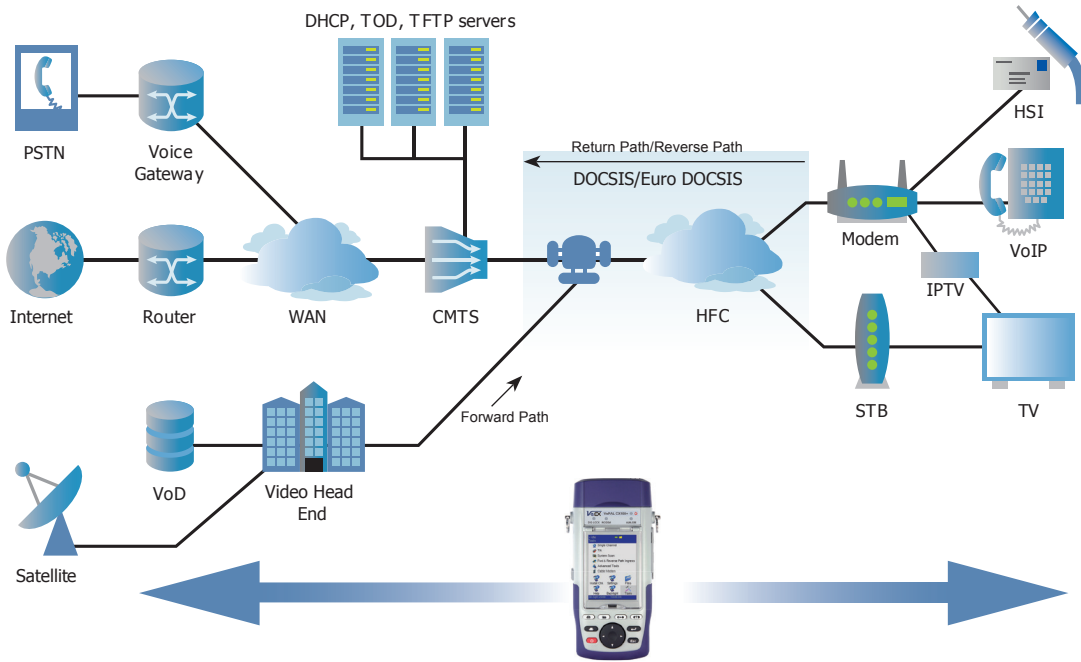

Features

Single Channel Measurement

Analog and digital carriers are very different in terms of signal content and power distribution and thus require the advanced SLM techniques supported in the CX150-D3+.

In **analog** mode, video and audio levels, V/A, Carrier to Noise (C/N) and Adjacent channels are measured. In **digital** mode, average power, MER, Pre-BER, Post-BER, Error seconds, and constellation diagram are displayed. User programmable location thresholds and test point compensation are useful utilities enabling fast, simple and automated testing of carrier signals.

Digital pictures do not show signal impairment until it is too late because the margin between acceptable quality and failure is quite small.

Constellation diagrams are a valuable tool to help detect the presence of noise, phase jitter, interference and gain compression, all of which impact overall signal quality and thus reduces Modulation Error Ratio (MER). Ideally, each of the 64 or 256 symbols should display a clean dot indicating a perfect QAM signal. Therefore, the size and shape build up of dots is indicative of problems which contribute to bit errors and even service disruption.

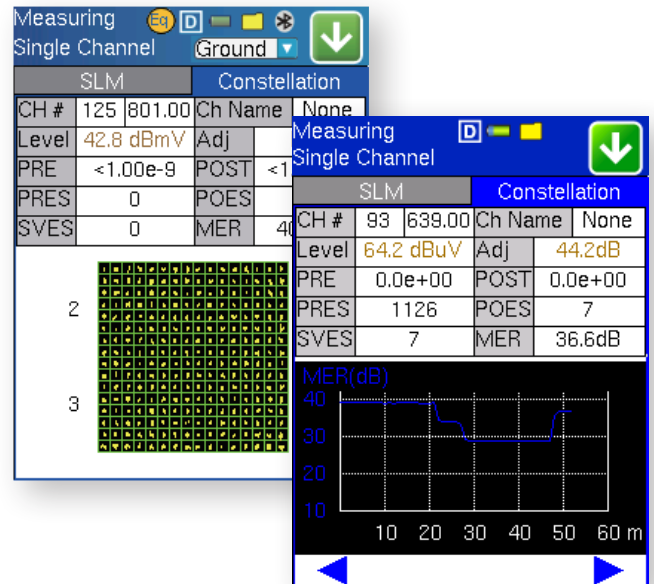
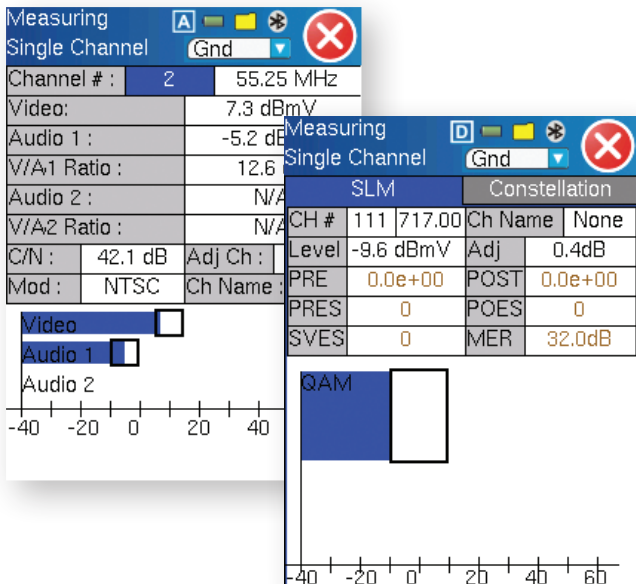

Installation Check

For new installations, up to 12 analog and 12 digital channels are checked against preset location thresholds. The feature is particularly useful to verify and turn up of service at new installations or after service is restored, Pass and fail conditions are color coded for easy interpretation and test results are clearly displayed. This automatic test procedure adds consistency to the final service qualification. A zoom function provides data measurement in greater detail. The CX150-D3+ can store up to 20 channel tables each of which can be pre-programmed with channels to be used for installation check.

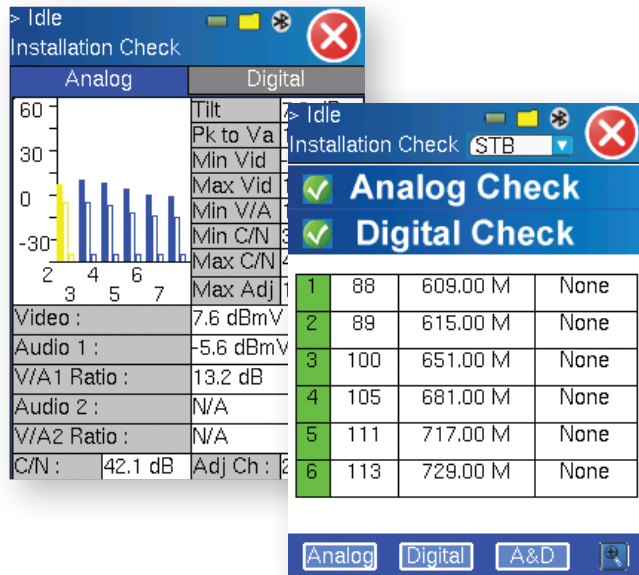

Tilt

Tilt measurements identify distortion over the frequency range allowing technicians to apply correct equalization or compensation to the HFC network. Up to six analog signals and digital carriers including DOCSIS channels can be predefined on a channel table and selected to perform the tilt measurement. The measurement can be performed between the lowest and highest channel or any user selectable channel by tapping the applicable bar on screen.

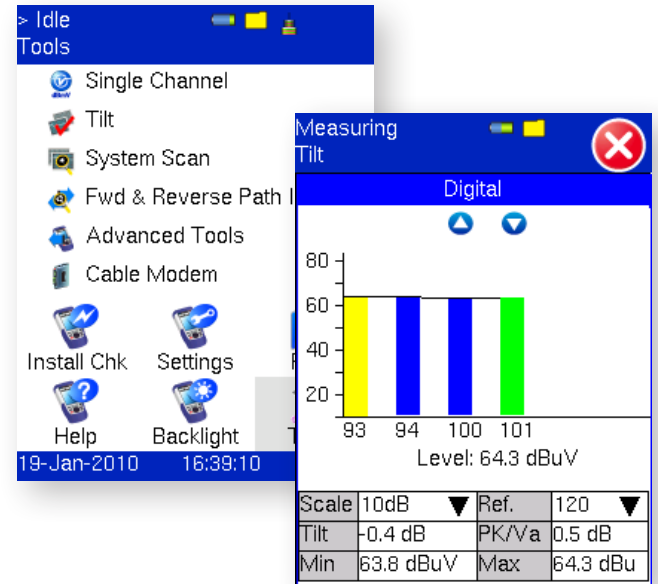

System Scan

Within seconds, all analog and digital channels at a service location are measured. Signal parameters including channel number, frequency, and power levels are measured.

Signal degradation or tilt can be easily pinpointed using on-screen markers and the zoom mode.

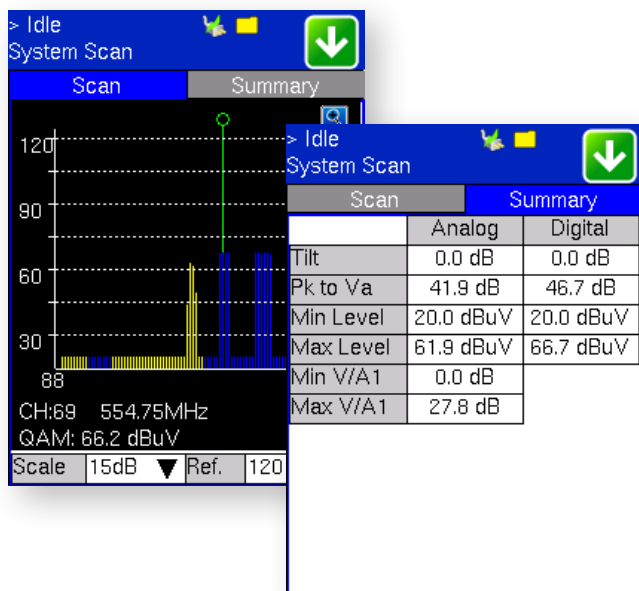

Forward/Reverse Path Ingress Scan

Poorly shielded coaxial cable and fault terminations (CPD) are sources and causes of ingress noise. Ingress is troublesome for return path communications in CATV networks due to the large number of subscriber-generated signals being funneled towards the headend. The combined and amplified interference is often responsible for service disruption, therefore the ingress test is a valuable tool to check the forward and reverse paths for interference and related problems.

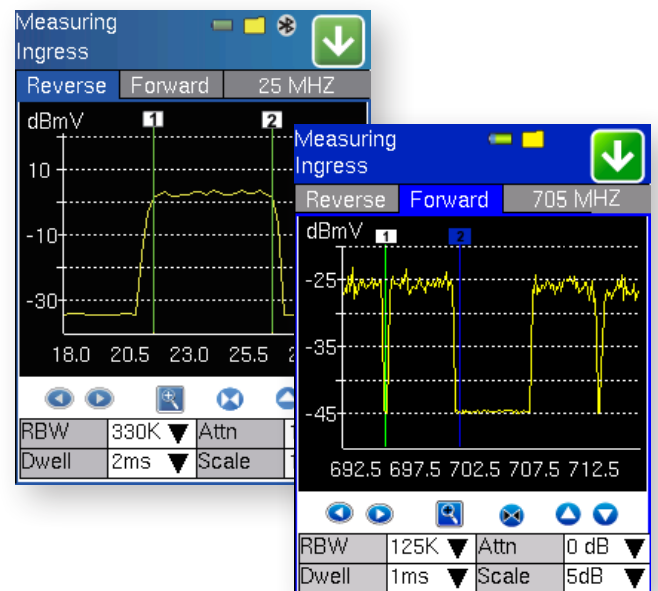

Reverse Path QAM Analysis

Reverse Path digital QAM signal is carefully analyzed for the QAM level, MER, pre and post BER, and error seconds. A unit with USG+FEC capabilities (CX3XX or CX120+) can be used to generate the QAM16/64/128/256 signal from a distant location for detailed analysis.

Adaptive Equalization – Modern Cable Modems, Set-Top Boxes and Cable Modem Termination Systems (CMTS) use advanced Adaptive Equalizer technology to compensate for complex in-channel frequency response impairments caused by micro-reflections, amplitude ripple and group delay occurring in the network. An adaptive equalizer adjusts its characteristics based on a single digitally modulated QAM carrier only as channel conditions change. This process maximizes or greatly improves the MER in the forward or reverse path.

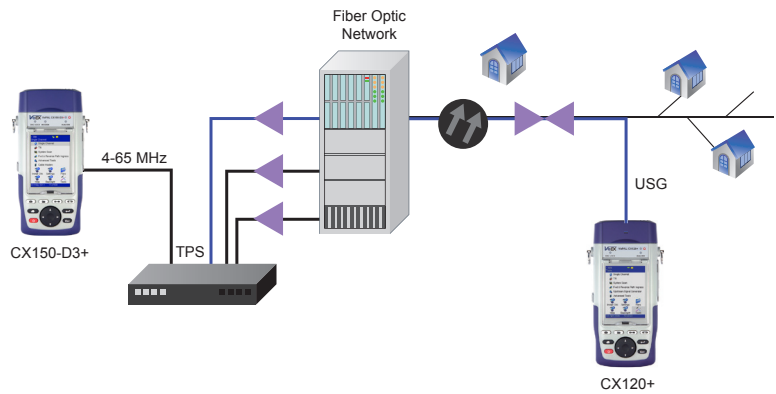

Equalized and Unequalized MER – Unequalized MER is typically measured before the adaptive equalizer and equalized MER is measured after the adapter equalizer, but often this circuitry resides in the QAM receiver and cannot be disabled. So while the adaptive equalizer does a great job improving MER of a QAM signal, it is also important for technicians to know how hard the system is working to ensure adequate margin for system degradation. The adaptive equalizer in the unit can be turned off to make troubleshooting marginal amplifiers, ingress, CPD and related impairments easier. In addition, Histograms for Level, MER, Pre/Post FEC, Pre/Post ES/SVES help monitor problems over a period of time.

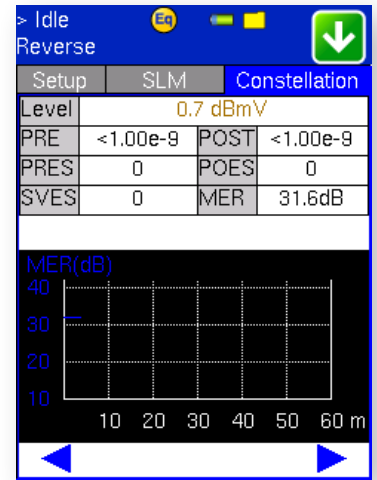
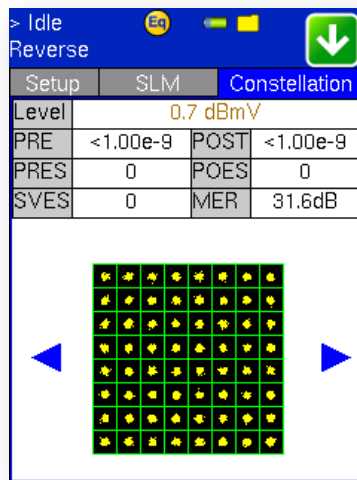

Upstream Signal Generator

Assessing the bandwidth characteristics of the reverse path used for the DOCSIS upstream communications has become vitally important. Transmitting a signal into the reverse path at a desired frequency, level, modulation type and symbol rate, allows the technician to evaluate phase and amplitude distortions resulting from misalignment occurring in the network. In particular, injected signals can also be used to determine if amplifier laser clipping occurs due to overloading. When used in conjunction with a QAM CATV spectrum analyzer, MER and related parameters can be assessed.

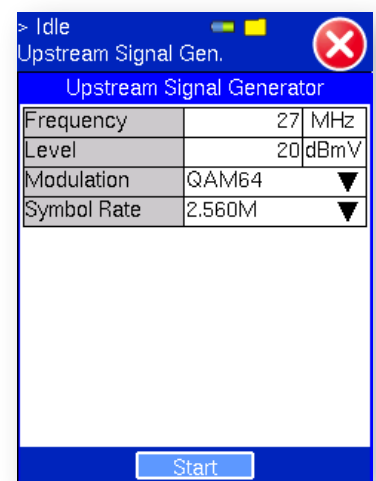
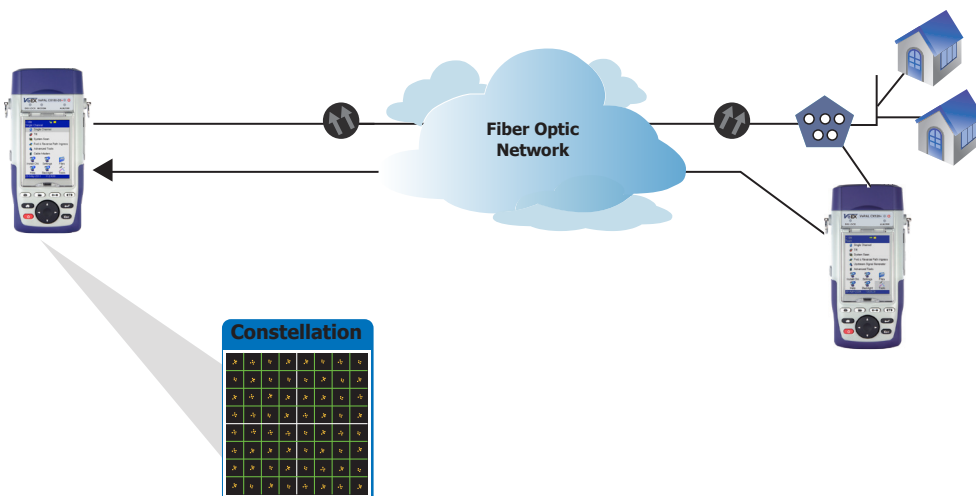

The CX150-D3+ transmits a reference signal of 5-65 MHz (Annex A) or 5-42 MHz (Annex B) to characterize the upstream. A choice of CW, QPSK, 16QAM, 64QAM and 256QAM modulation types with pre-defined symbol rates emulates DOCSIS cable modem transmission. Adjustable power level is useful to check amplifier performance resulting from overloading.

DOCSIS® 3.0/EuroDOCSIS 3.0 Cable Modem Emulation

The built-in DOCSIS/EuroDOCSIS cable modem provides a fast and reliable method to check Internet connectivity and test Triple Play services over the RF interface.

Simple Setup and Connection Summary

Technicians can test according to defined channel plans using default settings or the Media Access Controller (MAC) address and channel details can be configured manually as required. The modem ranges and connects with the Cable Modem Termination System (CMTS) and registers with various servers on the network, recording the entire process. A summary of the key Downstream and Upstream parameters including frequency, power level, UCD selection and IP server status are displayed so technicians can view problems quickly without spending valuable time scrolling through multiple test results and screens.

Downstream/Upstream Results

Downstream Power including the Signal-to-Noise Ratio (SNR) is measured, because too much noise on the cable results in data errors, even when received power level is within limits. During upranging, the modem's Transmit Power is adjusted in fine increments to the point where the CMTS receives the same signal level from all modems on a particular upstream channel irrespective of different cable losses. For technicians, the upranging power level is indicative of return path quality.

Registration Procedure

The vast majority of non-RF problems encountered in the field are IP-related, so it is very important for the technician to have a good insight to the registration process and IP connection status to various servers implemented in the network.

Once a communication link has been established with the CMTS, the modem obtains an IP address and the configuration file name from the DHCP server, including IP addresses of other important servers present on the network. If the modem is not provisioned on the network correctly, the DHCP process will fail forcing the technician to perform additional troubleshooting.

If the DHCP session is successful, the modem proceeds to download the configuration file from the Trivial File Transfer Protocol (TFTP) server which defines the subscriber's maximum Download and Upload speeds, Quality of Service (QoS) and Encryption settings. The Time of Day (ToD) server will also provide a timestamp to the modem if required.

RP Balancing

Return Path (RP) balancing is an alignment test for upstream amplifiers. The SLM and USG functions work in tandem to evaluate and align an amplifier's performance as a function of frequency. Programmable single tone, dual tone, or sweep through the entire return path spectrum is possible.

(N/A for Single Connector Version)

Finally, the modem sends a registration request to the CMTS including a list of its configuration properties. If the CMTS approves the settings, a successful registration response is generated. If the CMTS does not approve the settings, the registration request is rejected, and the modem will not be able to go online and transmit data.

The screenshot shows the 'Cable Modem Online' window with a 'Results' tab selected. The results table is as follows:

Setup	Results	IP	Link
CM IP	192.168.20.6		
Subnet	255.255.255.0		
DHCP Server	192.168.1.10		
Router IP	192.168.20.1		
TFTP IP	192.168.1.10		
Config File	CBE301 TE		
ToD IP	192.168.1.10		
Client IP	192.168.18.2		
Gateway	192.168.18.1		
Subnet	255.255.255.0		
DNS:	206.13.28.12		

Below the results table is an 'Events' log with the following entries:

Time	Events
18:25:26	Configuration File PASS
18:25:24	Time Of Day PASS
18:25:24	Configuration File In Prog
18:25:24	TFTP PASS
18:25:22	TFTP In Progress...
18:25:22	Time Of Day In Progress.
18:25:21	CM DHCP PASS
18:25:21	CM DHCP OK...

The interface also includes a 'Renew Client' button and a 'Page 2 of 4' indicator.

Baseline Privacy Infrastructure (BPI+) implemented by many cable operators, is used to encrypt and protect subscriber data and prevents non-paying subscribers from receiving service. The BPI registration process, when enabled, occurs immediately after the modem registers with the CMTS.

For diagnostic purposes, the built-in modem reports the entire registration process via intuitive screens and messages. A complete sequence of events and a log of IP addresses is displayed so the technician knows exactly what to look for rather than trying to understand all the intricacies of the registration process.

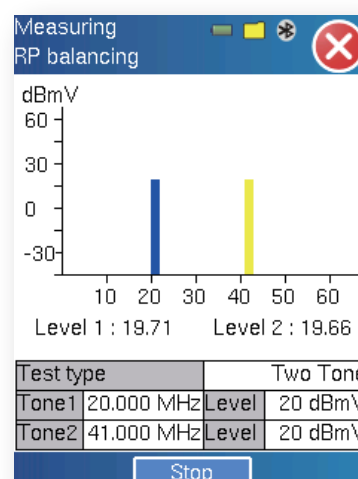

An embedded cable modem incorporating state-of-the-art technology, supports full upstream and downstream channel bonding, IPv6 addressing and Advanced Encryption Standard (AES) encryption used in next generation DOCSIS 3.0 and EuroDOCSIS 3.0 networks.

Dynamic bandwidth adjustment quickly allows technicians to lock to the channel bonding profile in service, so that up to four Upstream and eight Downstream channels can be tested including legacy single channel systems. Customers operating hybrid networks will benefit from the dual band design that supports both 8 MHz, Annex A and 6 MHz, Annex B modulation types and associated symbol rates.

Fitted with a Gigabit Ethernet interface, complete CPE emulation is achieved when the unit is configured in Pass Through mode. Technicians are able to perform full Triple Play service testing and troubleshooting at the highest possible bandwidth levels at both RF (WAN) and Ethernet (LAN) interfaces. The fast and reliable Internet connection provided by the modem can also be used to remote control the unit or it can be used to exchange test profiles and data between a server equipped with Reveal Productivity Suite software.

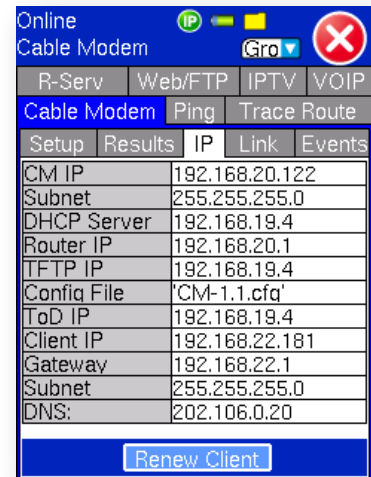
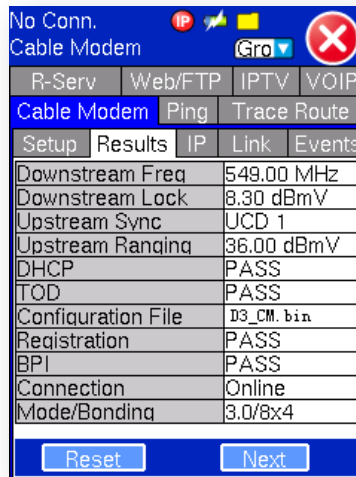
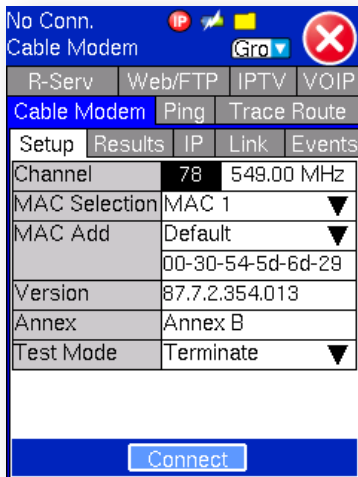

Link Statistics

Data rates up to 320 Mbps Downstream and 160 Mbps Upstream are supported and verified. The Transmit and Receive parameters of the modem including Frequency, Power level, SNR, Pre/Post BER, and Symbol rate are evaluated for each bonded channel. Dedicated Result tabs for Downstream and Upstream channels allows technicians to view bandwidth performance quickly and identify problematic channels or groups easily.

Channel Bonding

DOCSIS 3.0/EuroDOCSIS 3.0 technology provides a number of enhancements, most notably, channel bonding. Because channel bonding can be implemented independently on upstream channels or downstream channels, technicians quickly need to know these details when testing out in the field. The ability to do a quick spot check of frequency and power level in the Downstream provides a valuable insight into whether channels are balanced across the Downstream Bonding Group (DBG).

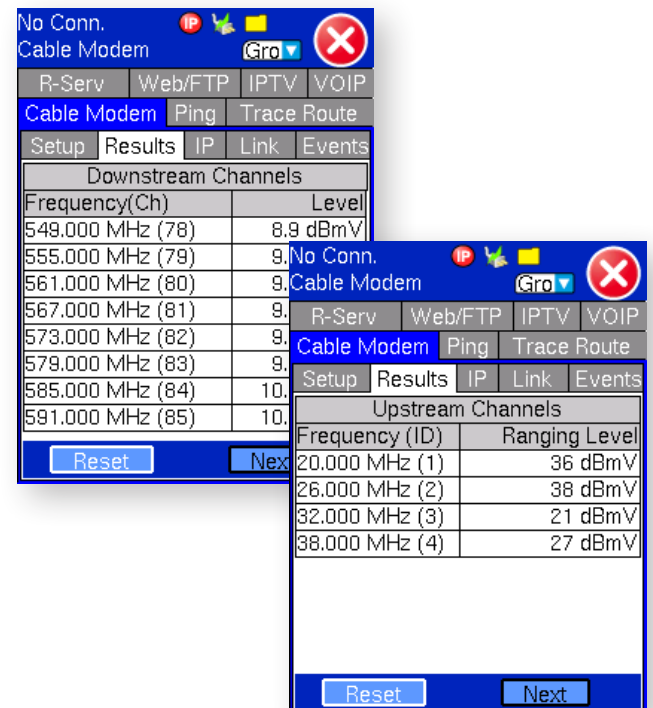

Advanced IP Testing

Triple Play services are IP centric, so IP test functions are no longer considered a luxury. On a daily basis, technicians verify network connections during service installation and restoration, so Ping test, Trace Route, ARP, Web browser, FTP throughput, and VoIP Call emulation have become routine measurements. IP verification on the CX series is possible over the DOCSIS Cable Modem and Ethernet management test ports, while a subset of these tools is available using the USB WiFi adaptor.

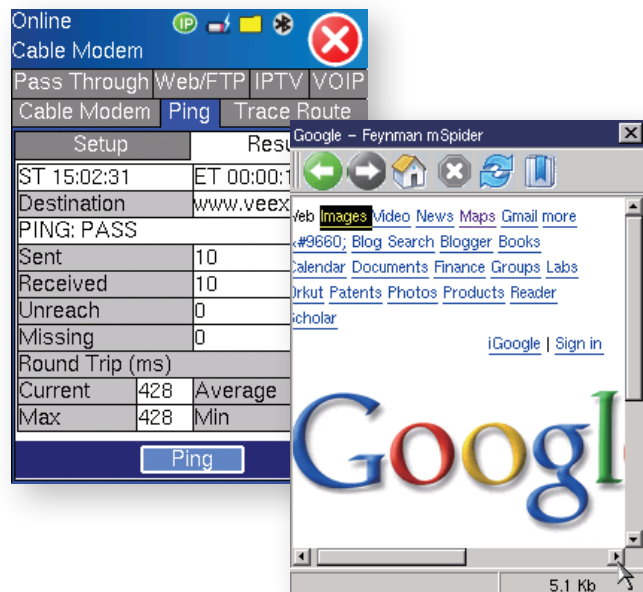

VeTest

VeTest via the cable modem interface enables download and upload throughput testing to various customer specific servers.

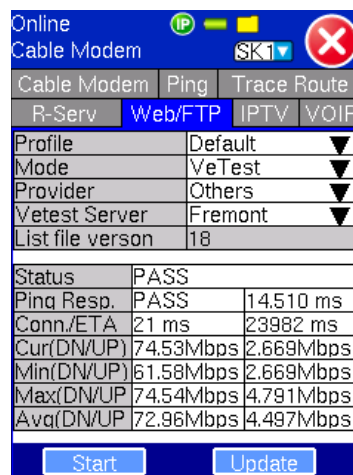

VoIP Testing

Take advantage of the three software options offering different test methods to verify and provision your VoIP network. Testing can be performed over any of the Ethernet or DOCSIS test ports.

VoIP Check – Simulates a VoIP call to the nearest router and measures the round trip MOS score and related VoIP parameters.

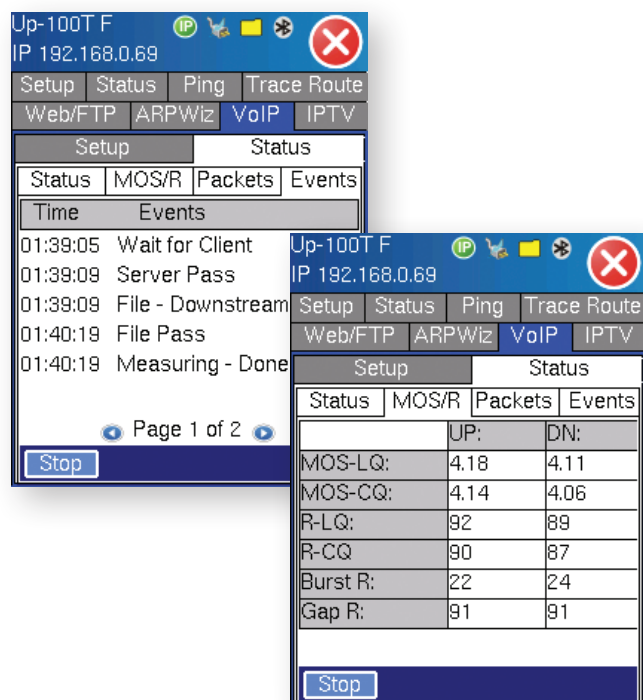

VoIP Expert – Generates industry standard wave files to verify MOS and R-factor values of upstream and downstream paths and includes QoS measurements such as packet jitter, packet loss, and delay. Compatible with all VeEX testers including VX1000 VoIP server software.

VoIP Call Expert – Emulates an IP phone and can place and receive calls using SIP or H.323 protocols. Comprehensive Codec support and call destination options verify voice encoding and translation provisioning. Real-time evaluation of subjective voice quality (MOS and R-factor) is made possible using the Telchemy® test method.

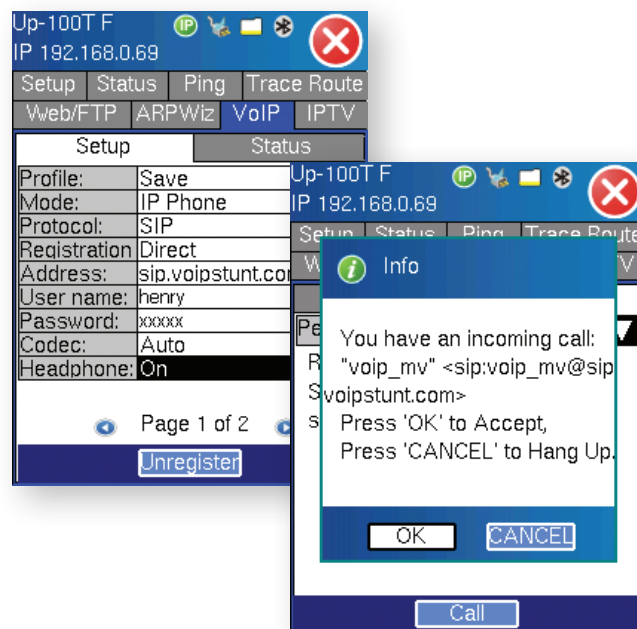

Net Wiz

Ethernet network installation is simplified using this basic, yet powerful feature. "Sniff" the network using the one-touch discovery feature. Identify routers, gateways, printers, PCs and other devices connected to the network within seconds.



WiFi Wiz

All VePAL products adopt a USB WiFi adaptor to make 802.11 b/g wireless installations a simple task. Scan for available networks or perform signal strength and quality measurements to determine the best location for a new wireless access point. The IP Ping capability ensures the wireless network is properly installed and configured. A full suite of IP testing features is supported.

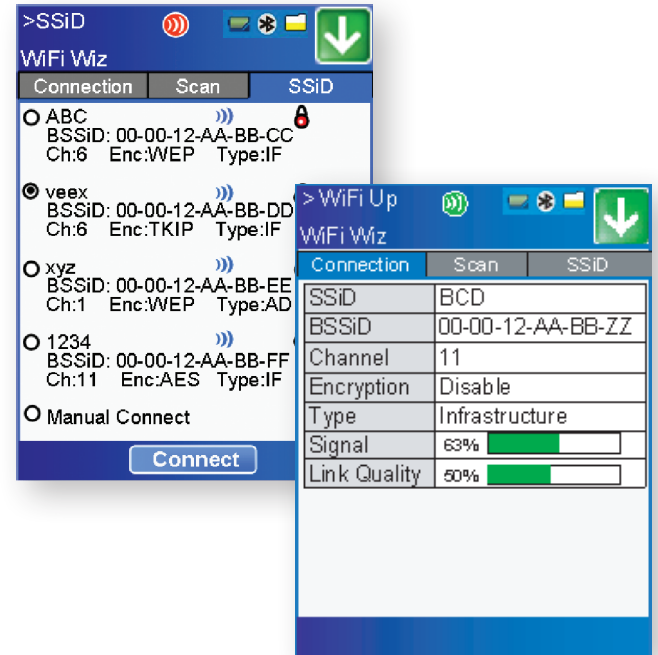

Bluetooth

All VePAL products support a micro USB Bluetooth adaptor offering a wireless connectivity up to 10 meters or 30 feet. Ultra compact and portable, the adaptor provides an untethered connection between the test set and other Bluetooth compatible devices such as a Notebook PC or cell phone, so a technician can transfer test result files quickly and easily without having to bother with memory sticks or Ethernet connections.

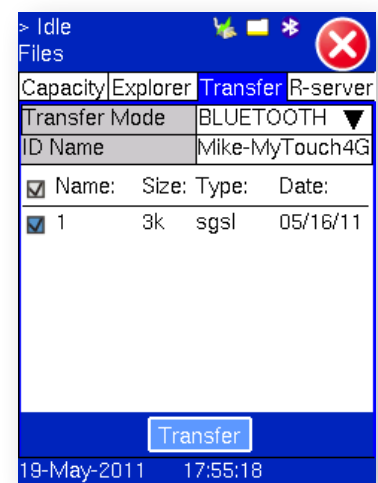
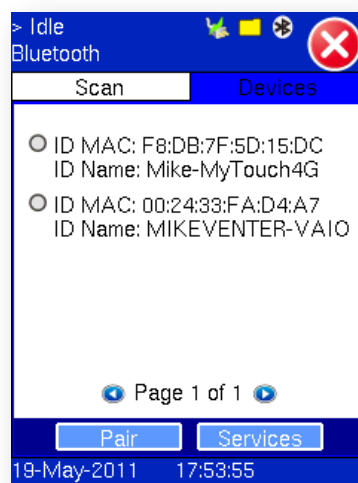
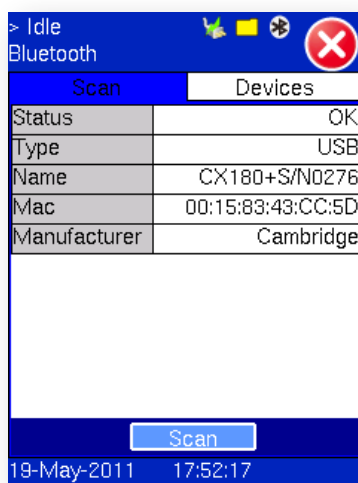
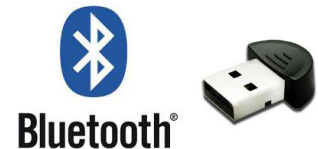

ReVeal Server Productivity Suite

A software application specifically designed for medium-to-large CATV operators facing the enormous challenge of coordinating hundreds of installations per day, collecting the field test results for billing/record purposes and having to maintain a large inventory of test sets in parallel. When used in conjunction with the Home Installation Process (HIP) and Signature Pad features, the application becomes a powerful tool to reduce customer call-backs and associated truck rolls, maximizing workforce efficiency and lowering operational costs.

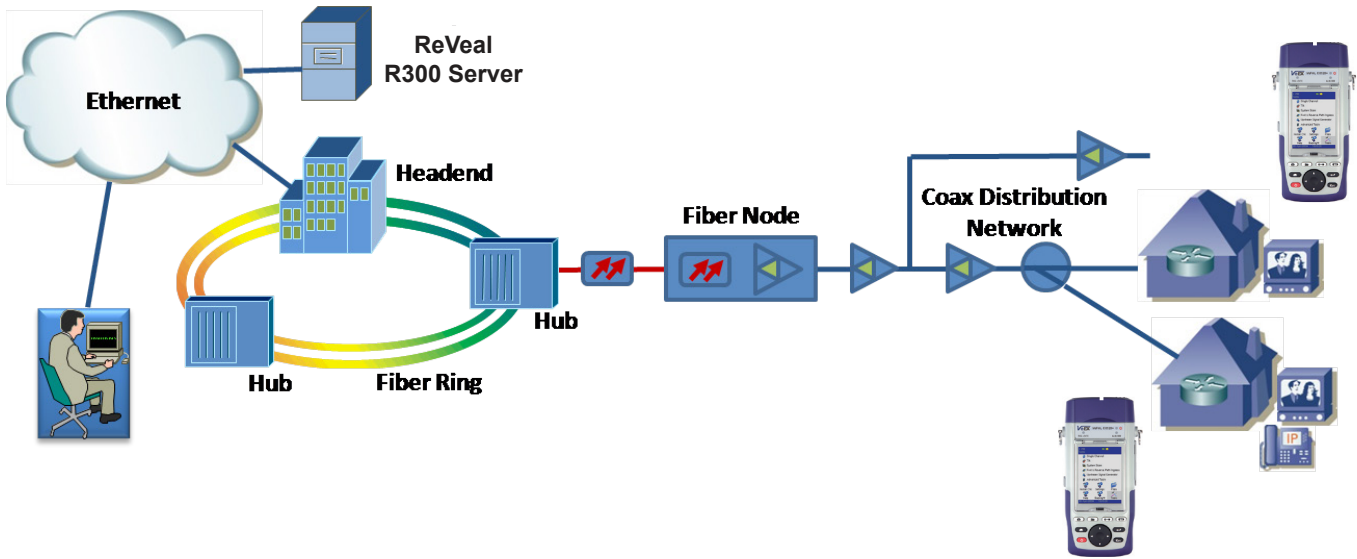

Home Installation Process (HIP)

A customized test procedure that can be downloaded and programmed into each test set. The step-by-step script eliminates guesswork and rogue installation practices ensuring consistent service turn-up and delivery. This disciplined technique ensures the “Birth Certificate” of each new installation conforms to operating guidelines and ISO quality standards.

Advanced Management

Authorized test sets register with specific ReVeal R300 Server/s to download new channel tables, test profiles, measurement thresholds and job cards. Test results can be uploaded via LAN interface or DOCSIS connection running over the existing RF network. Signature Pad electronically captures the customer signature which is automatically appended to the test results upon work order completion.

Benefits

- Centralized storage of test profiles, software versions, and measurement thresholds
- Registered test sets are informed of new test profiles, software versions and channel tables
- Test set software versions are maintained and synchronized
- Results are collected electronically while technician is on site, thus billing transactions can be processed sooner
- Operates with Operator and Contractor owned test sets giving operational statistics for both activities
- Provides theft prevention, test set lockout, time lock and other security features

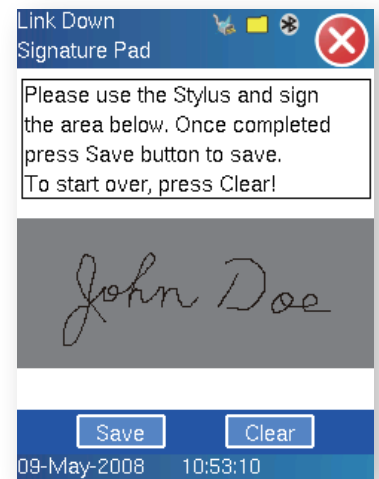

ReVeal CXM PC Tool

A software package shipped standard with each CX test set. Channel tables, location thresholds, and other installation data can be created and edited on a PC for upload to the test set via USB, LAN or DOCSIS connection. Test results can be downloaded and saved to a PC, where test data management and report generation can be performed. Users are able to check and upgrade their test sets without having to return the unit to the supplier, thus reducing downtime.

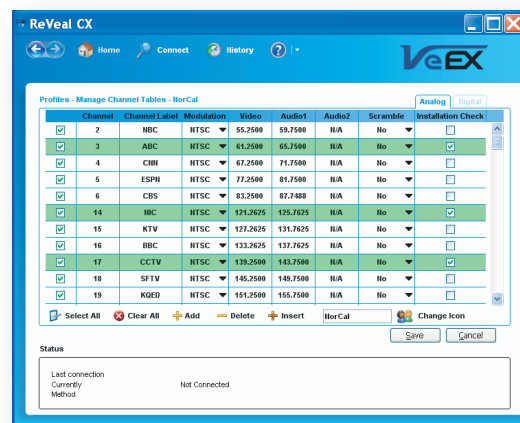

Specifications

Measurements

Frequency Range: 5 to 1000 MHz
 Level Input Range: -45 dBmV to +55 dBmV
 Level Accuracy: ± 1.5 dB typical
 Amplitude Resolution: 0.1 dB
 Downstream Modulation: 64/256 QAM Annex A/B/C
 Digital Lock Range²: -15 dBmV to +50 dBmV
 C/N Range: 50 dB
 C/N Accuracy: ± 2.0 dB typical
 MER: 21 to 40 dB (± 1.5 dB typical)
 Downstream BER Range: 1×10^{-9} to 9×10^{-3}
 Input Impedance: 75 Ω

Single Channel Measurements

Analog signal measurements: Video and audio Power level, Video-to-audio ratio, adjacent channel ratio, C/N ratios
 Digital signal measurements: QAM power level, MER, Pre/Post BER, constellation, deep interleave, adjacent channel ratio

Installation Check

Measurement locations: Tap, Ground Block, Set-Top Box
 Analog measurements: Up to 12 channels per channel table (including tilt, peak-to-valley, min/max video level, min video-to-audio ratio, min/max C/N ratio, max adjacent channel ratio)
 Digital measurements: Up to 12 channels per channel table (including tilt, peak-to-valley, min/max QAM level, MER, max adjacent channel ratio, pre-BER, post-BER)

System Scan

Scan on all channels in the active channel plan
 Analog measurements: Video and audio power levels, video-to-audio ratio, tilt, peak-to-valley, min/max video level, min/max video-to-audio ratio
 Digital measurements: QAM power level, tilt, peak-to-valley values, min/max QAM level

Forward and Reverse Path Ingress Scan

Forward

- Scan Range: 55/108 MHz¹ to 1000 MHz
- Resolution: minimum 62.5 kHz

Reverse

- Scan Range: 5 to 42 MHz / 65 MHz¹
- Resolution: minimum 125 kHz

Forward and Reverse

- Resolution Bandwidth: 125 kHz, 330 kHz, 1 MHz
- Attenuation Range: 0 to 40 dB, 10 dB/step
- Range with Attenuation: -45 dBmV to +55 dBmV
- Dynamic Range: 50 dB

Reverse Path QAM Analysis

Requires far end device with USG+FEC option (CX3XX or CX120+)
 Reverse scan range: 5 to 42 MHz/65 MHz¹
 Minimum lock level: -5 dBmV
 QAM level, MER, pre/post BER
 Constellation diagram

Upstream Signal Generator

Modulation: QPSK, QAM16/64/256, CW
 Output signal level: 8 to 58 dBmV (CW typical)
 Frequency range: 5 to 65 MHz, 1 MHz step

Notes

¹ Annex A

² Typical range with QAM64 modulation

Cable Modem

DOCSIS/EuroDOCSIS 3.0/2.0/1.1 compliant

Downstream/Receiver

- Demodulation: QAM64/256/1024
- Frequency Range
 - DOCSIS: 88 MHz to 1002 MHz
 - EuroDOCSIS: 108 MHz to 1002 MHz
- Maximum Speed: 320 Mbps (EuroDOCSIS with 8 D/S bonding)
- Channel Bonding: Up to 8 channels (contiguous or non-contiguous)
- Bandwidth
 - DOCSIS: 6 MHz
 - EuroDOCSIS: 8 MHz
- Input Power Level: -15 dBmV to +15 dBmV

Upstream/Transmitter

- Modulation: QPSK, QAM8/16/32/64/128
- Frequency Range
 - DOCSIS: 5 to 42 MHz
 - EuroDOCSIS: 5 to 65 MHz
- Maximum Speed: 160 Mbps (EuroDOCSIS with 4 U/S bonding)
- Channel Bonding: Up to 4 channels
- Output Signal Level
 - QAM32/64: +8 to +54 dBmV
 - QPSK: +8 to +58 dBmV
 - S-CDMA: +8 to +53 dBmV

General

- IPv4 and IPV6 support
- DHCP client obtains IP and DNS server address from DHCP server automatically
- Time of Day (ToD) support for local and MSO time synchronization
- TFTP Client support for cable modem configuration file download
- Security: BPI+ and AES support
- Pass-Through testing (1000BaseT port): Verify high bandwidth data transfer between PC and Network

Advanced IP Testing

Ping, Trace Route, ARP, FTP/Web tests. These are done via the LAN Management port or via Cable Modem emulation.

VoIP Testing

VoIP Check

- Simulates VoIP call to the nearest router/CMTS
- Round Trip MOS score

VoIP Expert

- MOS and R-factor measurement
- Packet Statistics: packet loss, jitter, delay

VoIP Call Expert

- VoIP call setup with VoIP USB adaptor
- Supports SIP and H.323 protocols
- Codex: G.711U, G.711A, G.723, G.729, Auto

NetWiz

Available on LAN Management port
 Network device discovery
 Auto Ping verification

WiFi Wiz

Supports 802.11 b/g
 SSID detection, infrastructure, Ad-hoc, and encryption
 Signal strength and signal quality
 IP connectivity (Ping, Trace Route, FTP upload/download, Web Test, VoIP Check and VoIP Expert)

General Specifications

Size	210 x 100 x 55 mm (H x W x D) 8.25 x 3.75 x 2.25 in
Weight	Less than 1 kg (less than 2.2 lb)
Battery	Lilon smart battery, 2600mAh, 10.8VDC
Operating Time	Standard > 4 hours, Standby > 12 hours Extended > 8 hours, Standby > 24 hours
AC Adaptor	Input: 100-240 VAC, 50-60 Hz Output: 15VDC, 3.5A
Operating Temperature	-10°C to 45°C (14°F to 113°F)
Storage Temperature	-20°C to 70°C (-4°F to 158°F)
Humidity	5% to 95% non-condensing
Display	3.5" QVGA 320x240 full color touchscreen
Ruggedness	Survives 2m (6 ft) drop to concrete on all sides
Water resistance	May be used in light rain
Interfaces	USB 2.0 RJ45 10/100/1000 BT Bluetooth (optional)
Languages	Multiple languages can be supported



VeEX Inc.
2827 Lakeview Court
Fremont, CA 94538 USA
Tel: +1.510.651.0500
Fax: +1.510.651.0505
www.veexinc.com
customercare@veexinc.com

© 2014 VeEX Inc. All rights reserved.
VeEX is a registered trademark of VeEX Inc. The information contained in this document is accurate. However, we reserve the right to change any contents at any time without notice. We accept no responsibility for any errors or omissions. In case of discrepancy, the web version takes precedence over any printed literature.
D05-00-060P A00 2014/03